

□ 10までのかず・すうじ

		なまえ
がつ	にち	

おなじ かずを せんで おすびましょう。すうじを なぞりましょう。

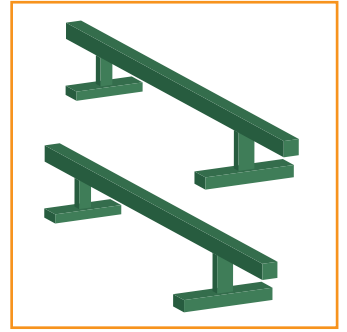
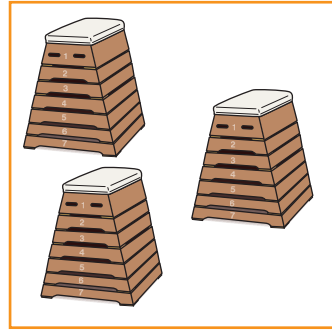
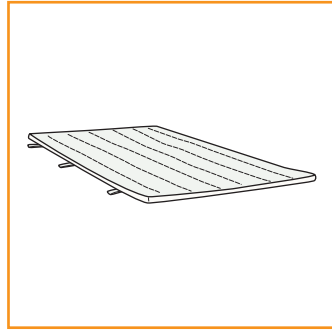
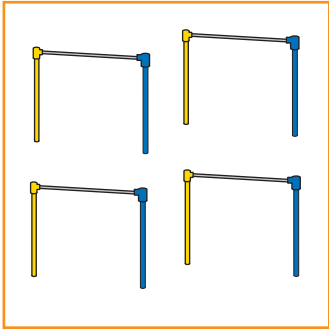

し
(よん)



に



いち



さん

